

Multi-Channel CCD Spectrometers

(Part Number: ISP-VIS-MC006-A)

FEATURES

- Multiple (6) spectral channels in one compact package
- No moving parts
- High spectral resolution
- High throughput
- USB2.0 interface
- No external power required
- Trigger input
- Full-featured SDK
- GPIOs for interfacing with other equipment

APPLICATIONS

- LED sorting
- Display measurement
- Lab research
- Process control
- Environment monitoring

PRODUCT DESCRIPTION

Multi-channel spectrometers are used to monitor or measure multiple samples or sources simultaneously. Traditionally, multi-channel imaging spectrometers have been expensive and bulky instruments used only in demanding laboratory and industrial applications. Mightex has leveraged the state-of-the-art optics and CCD cameras to bring to the market a compact and low-cost multi-channel fiber spectrometer that features high spectral resolution and high light throughput.

At the heart of Mightex multi-channel spectrometers is a high-throughput flat-field imaging spectrograph. Multiple input fibers, each represents an independent signal channel, are aligned along the input slit of the imaging spectrograph. Spectrum of each channel is dispersed by a high-efficiency diffraction grating and then imaged on to a 2D CCD sensor. Light from each channel occupies different rows on the CCD sensor. All channels are exposed simultaneously, then rows associated with each channel are binned together to produce a spectrum for the channel. Fiber channels are spaced out properly to essentially eliminate crosstalk between adjacent channels.

The standard CCD camera features a 1/2" 1.3MP Sony ICX205 imager with a 12-bit ADC. Exposure time (integrating time) can be varied between 50us and 200s. The electronics hardware also includes trigger input and four programmable digital I/Os for interfacing with other equipment such as a light source. The spectrometer is controlled through a USB2.0 interface which also supplies all the electric power needed to operate the spectrometer. Mightex also integrates other cameras to build custom multi-channel spectrometers.

Input ends of the fibers are connectorized with SMA905 connectors. Sleeves are available to connect the fibers to other SMA connectors.

Standard software package includes a full-featured multi-channel spectrometer PC software as well as a software development kit (SDK) for further software development. The software also supports radiometric calibration and photometric calculations.

PERFORMANCE SPECIFICATIONS

Parameters	Specification	Unit
Model	ISP-VIS-MC006-A	-
Number of Channel	6	-
Optical Platform	F/2 High-resolution flat-field imaging spectrograph	-
Wavelength Range	380 ~ 780	nm
Resolution ¹	1.2	nm
Order Sorting Filter	Long-pass	-
Entrance Slit	5 (also available: 10, 25, 50, 100, 200 or no slit)	μm
Input Fiber Connectors	SMA 905	-
Input Fiber NA	0.22	-
Detector	Sony ICX205AL	-
Pixel Number	1,392 x 1,040	-
Pixel Size	4.65 x 4.65	μm
Effective Pixel Well Depth ²	200,000	electron
Signal-to-noise Ratio	1,000:1(at full scale)	-
A/D Resolution	12	bit
Integration Time	0.05 to 200,000	ms
Frame Rate	15 @ 8bit, 9 @ 12bit	fps
Hardware Gain	6 ~ 43	dB
GPIO	4 programmable digital I/Os	-
Trigger Input	Yes	-
Trigger Delay	< 25	μs
PC Interface	USB 2.0	-
Trigger/GPIO Interface	DIN8	-
PC Operating System	Windows 2000/XP/Vista/7/8	-
Power Consumption	1.8	W
Weight	840	g

(1) With a 10μm slit; (2) After binning.

Spectral Resolution(FWHM, nm) vs. Slit Width						
Slit Width(μm)	5	10	25	50	100	200
ISP-VIS-MC006-A-XXX	1.1	1.2	1.7	2.4	4.0	7.1

NOTE: Entrance slits are fixed and are NOT interchangeable in ISP multi-channel spectrometer products.

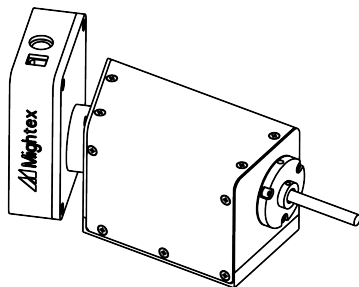

Multi-Channel CCD Spectrometers

(Part Number: ISP-VIS-MC006-A)

EXAMPLE OF GRAPHICAL USER INTERFACE

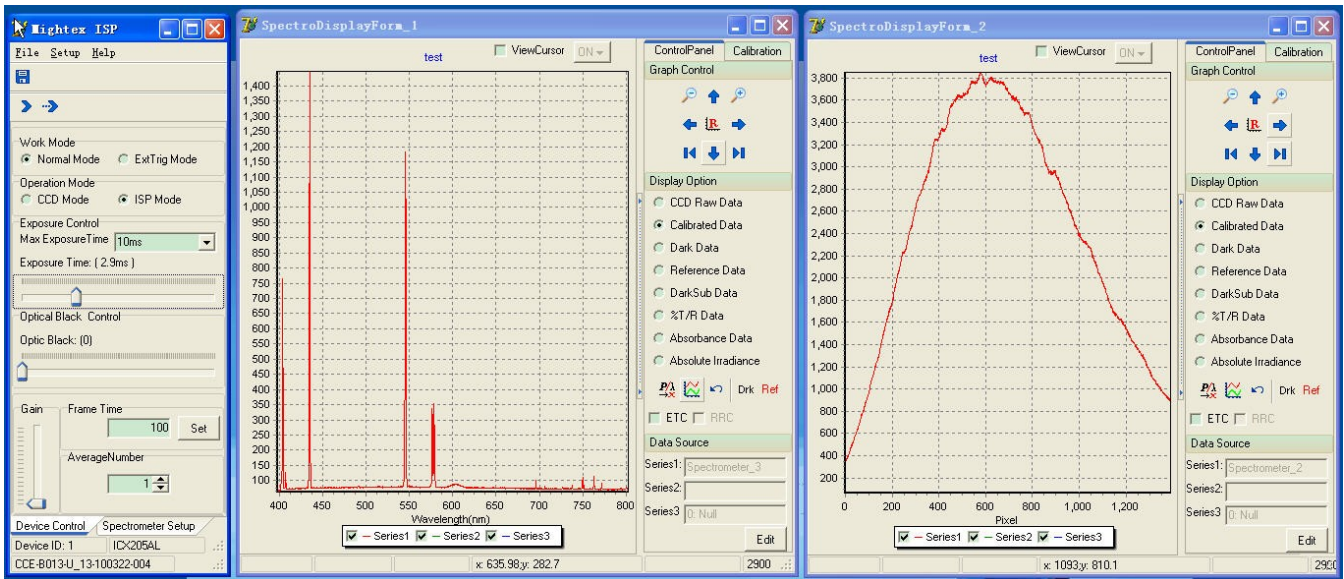

INSTALLATION DRAWING

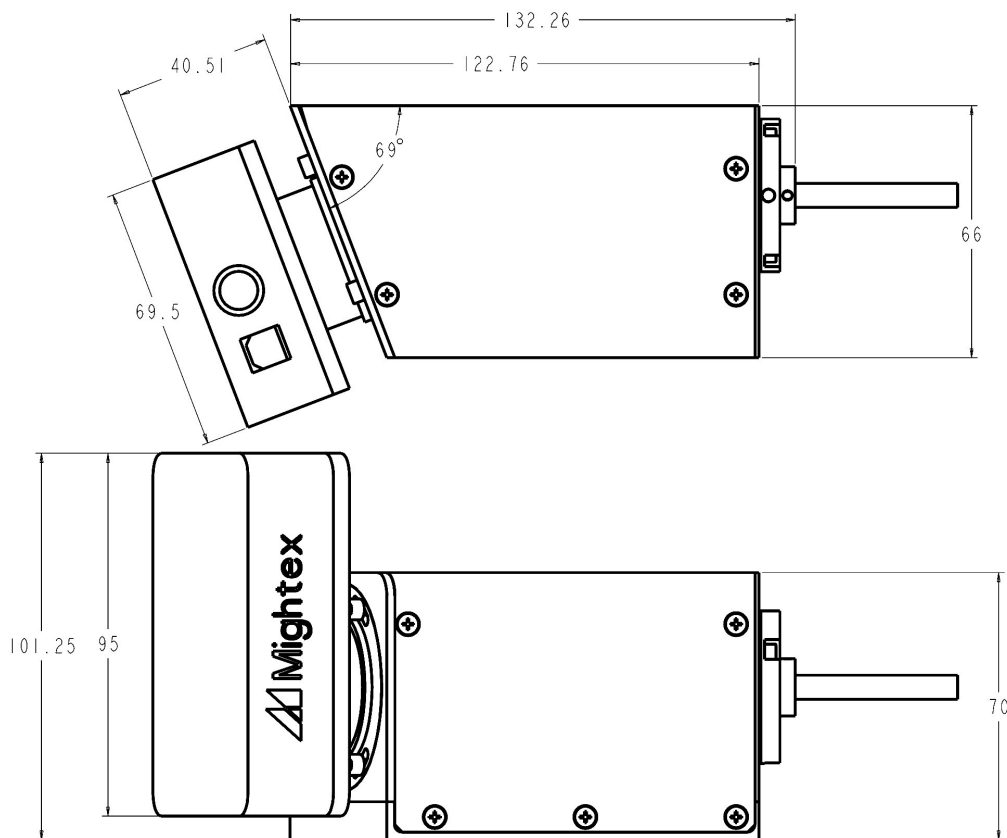

With a world-class OEM design team, Mightex offers a broad range of customized solutions in order to meet individual customer's unique requirements. Please call 1-416-840 4991 or email sales@mightex.com for details.